

ASSEM

Für diese technischen Unterlagen behalten wir uns alle Rechte nach DIN ISO 16016 vor				Maßstab: 1:1					
				Maße ohne Toleranzangabe nur zur Information					
				Bear.	16.11.2021	KUDLA	Benennung:	NICHT Freigegeben!	
				Gepr.			Rollenband AT		
				Norm			Tatprof MP72		
				DIS:	119673,ZDR,DRW,00		Zeichnungsnummer:	Blatt	
				Dr. Hahn [®] TÜRBÄNDER. MADE IN GERMANY.			233A0000		1
									6
In.	Änderung	Datum	Name	Urspr.:			Ers.f.	Modell-Nr. 233A0000	

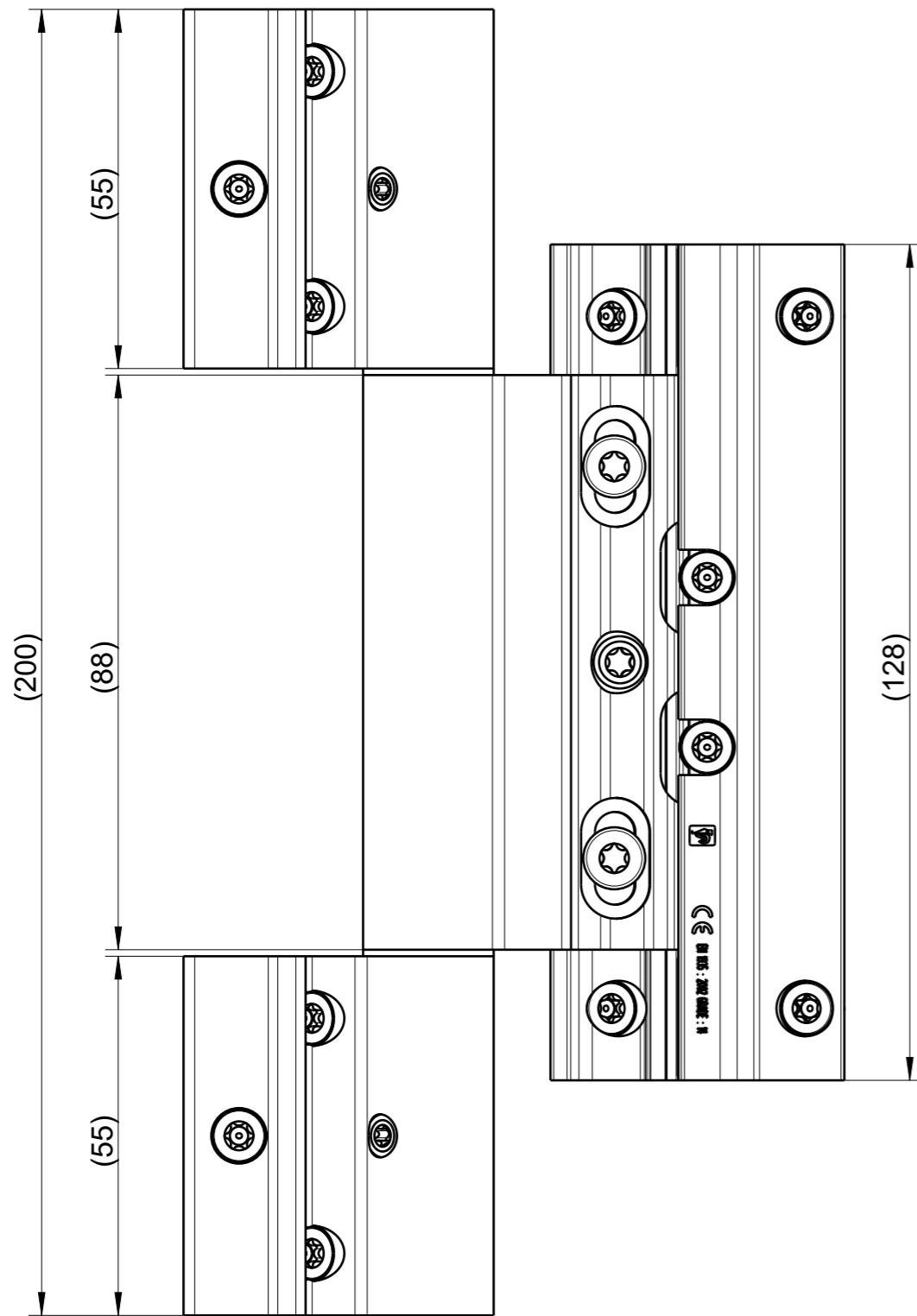

Pos	Menge	Benennung	Sachnummer
1	2	RBT AT 6 / 13,5	233F0000
2	2	Lagerbuchse FBT exzentrisch schwarz	R600K0001
3	1	FBT Einheit komplett Rollenband AT	233B0000
4	1	Lagerbolzen	R600E0007
5	2	Gewindestift M6x5-TX15 A4 oder A2	R400E0010
6	12	Bef.-Schraube RB-AT 4,8x16	R700E0000

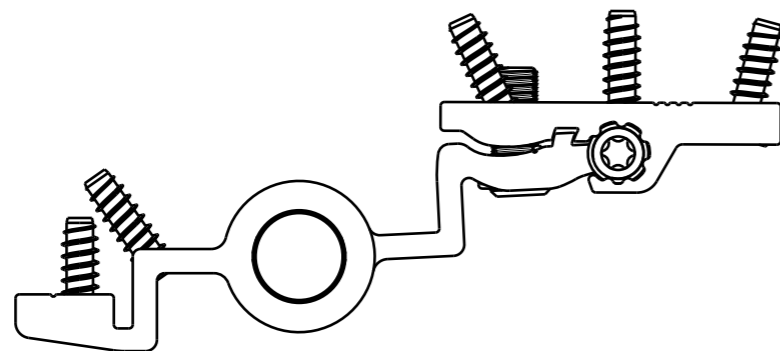
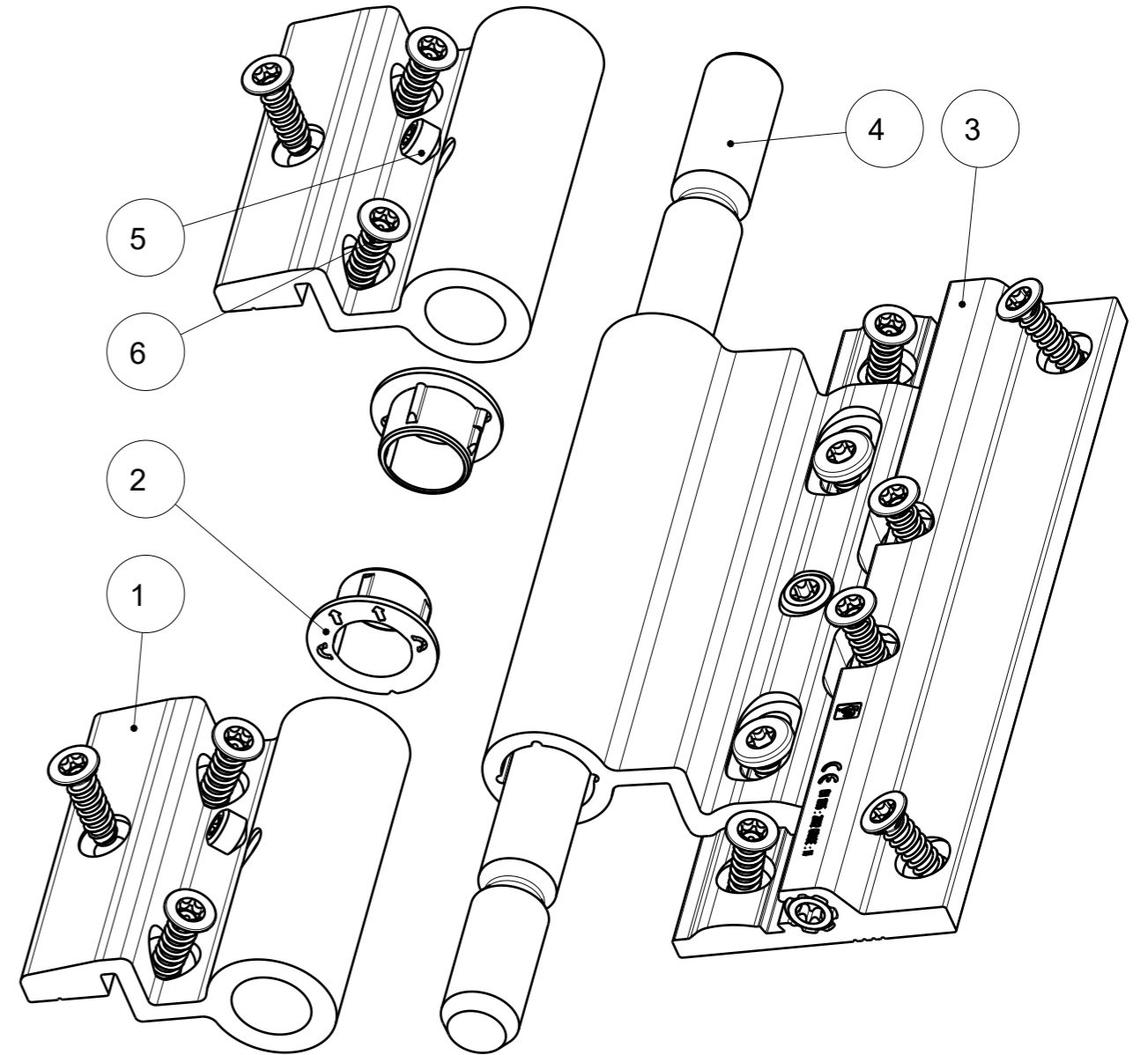

ASSEM

Für diese technischen Unterlagen behalten wir uns alle Rechte nach DIN ISO 16016 vor				Maßstab: 1:1		
				Maße ohne Toleranzangabe nur zur Information		
		Datum	Name	Benennung: RBT AT		
		Bear.	16.11.2021	KUDLA	Tatprof MP72	
		Gep.				
		Norm				
		DIS:	119673,ZDR,DRW,00			
		Dr. Hahn TÜRBÄNDER. MADE IN GERMANY.			Zeichnungsnummer:	Blatt
					233A0000	
In.	Änderung	Datum	Name	Urspr.:	Ers.f.	Modell-Nr. 233A0000
					6	

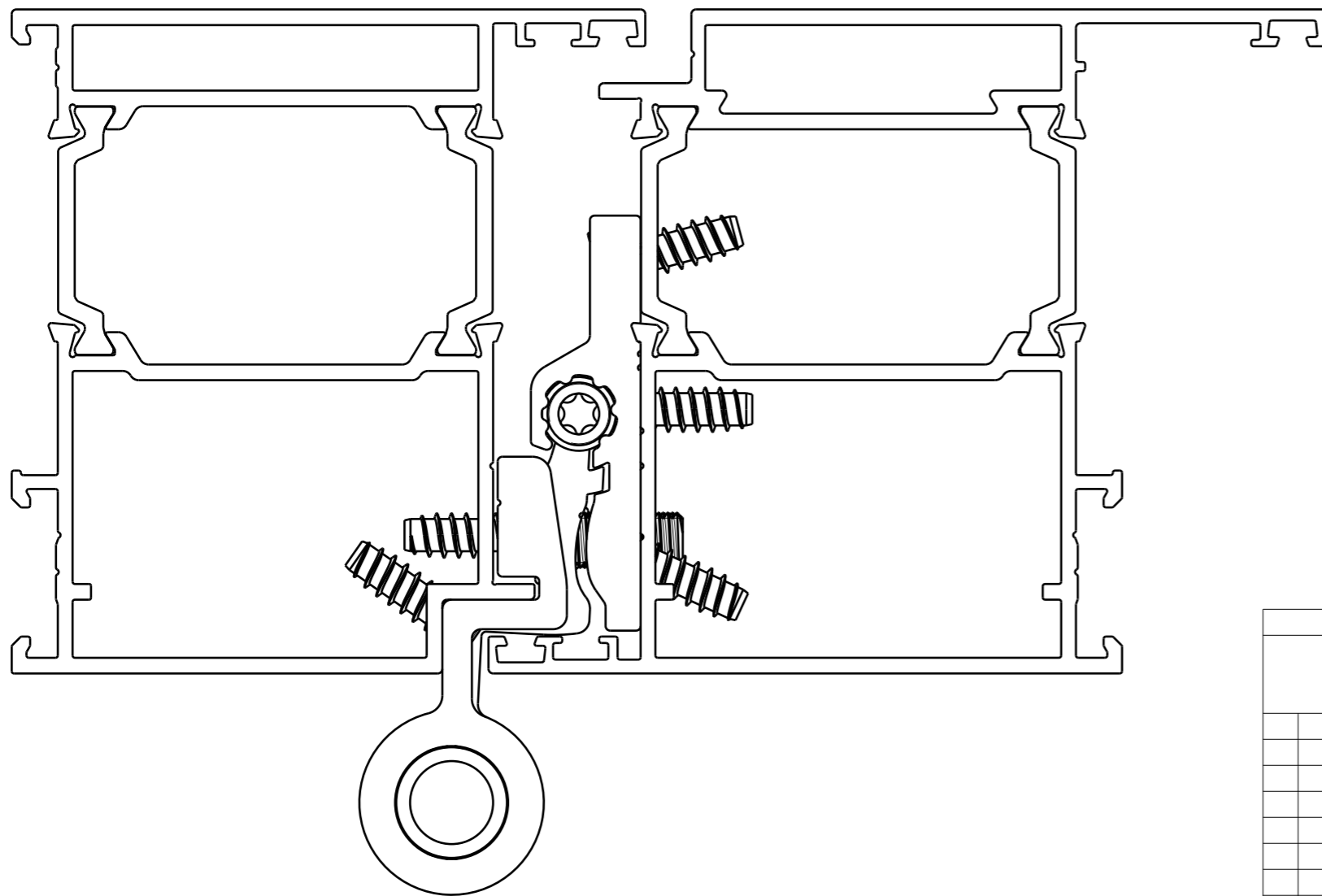
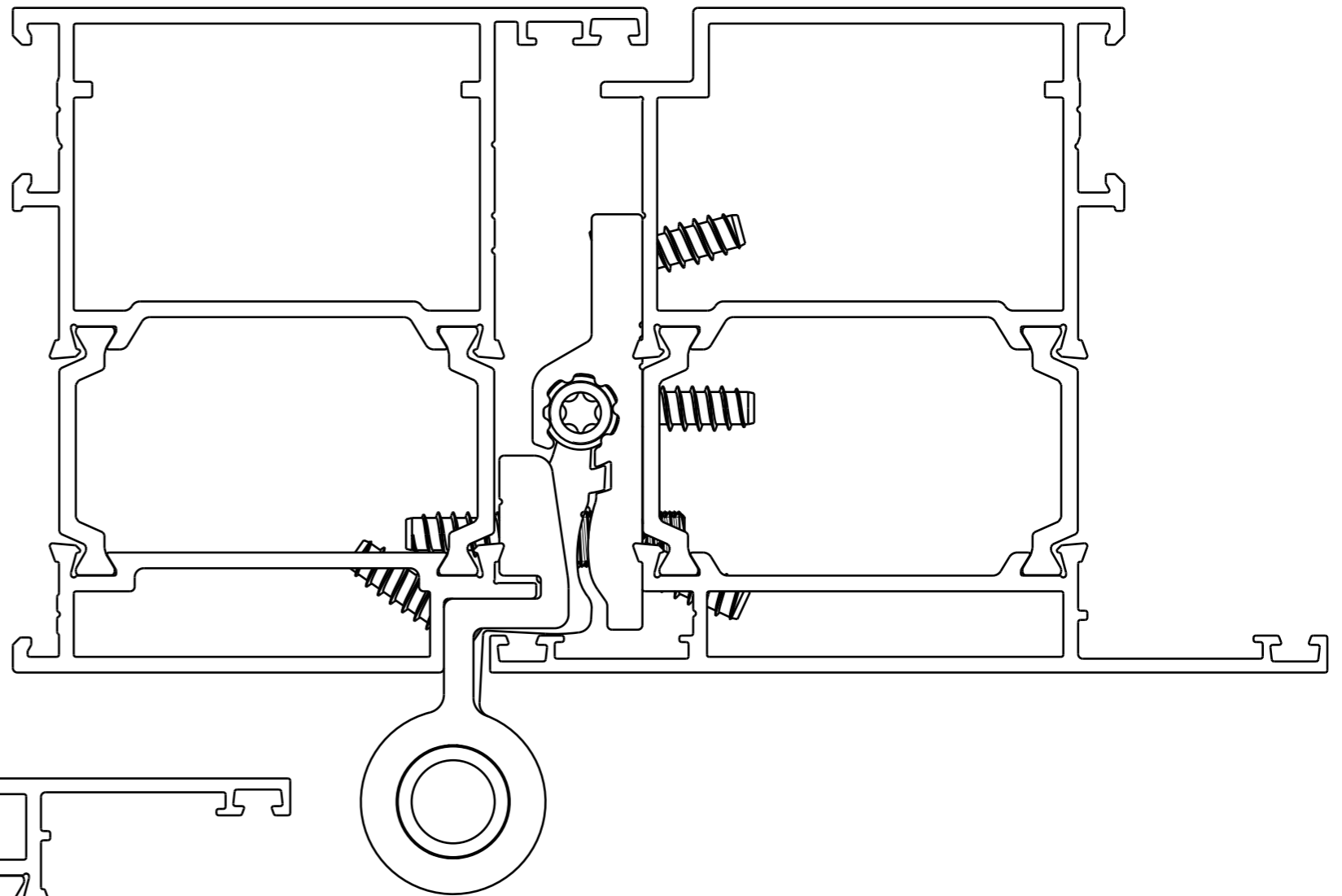

Für diese technischen Unterlagen behalten wir uns alle Rechte nach DIN ISO 16016 vor				Maßstab: 1,5:1	
				Maße ohne Toleranzangabe nur zur Information	
				Datum	Name
				Bear.	16.11.2021 KUDLA
				Gepr.	
				Norm	
				DIS:	119673,ZDR,DRW,00
				 Dr. Hahn [®] TÜRBÄNDER. MADE IN GERMANY.	
				Benennung: Rollenband AT	
				Tatprof MP72	
				Zeichnungsnummer: 233A0000	
				Blatt	
				3	
				6	
In.	Änderung	Datum	Name	Urspr.:	Ers.f. Modell-Nr. 233A0000

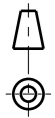

ASSEM

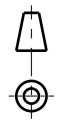
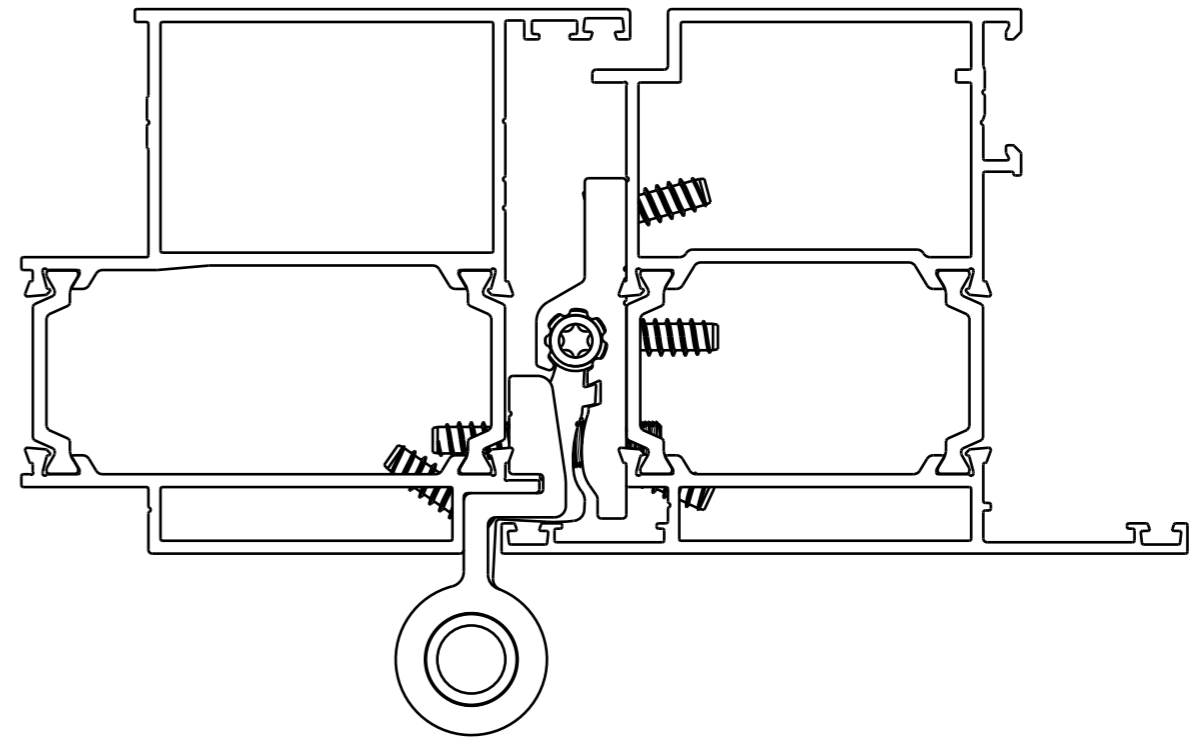
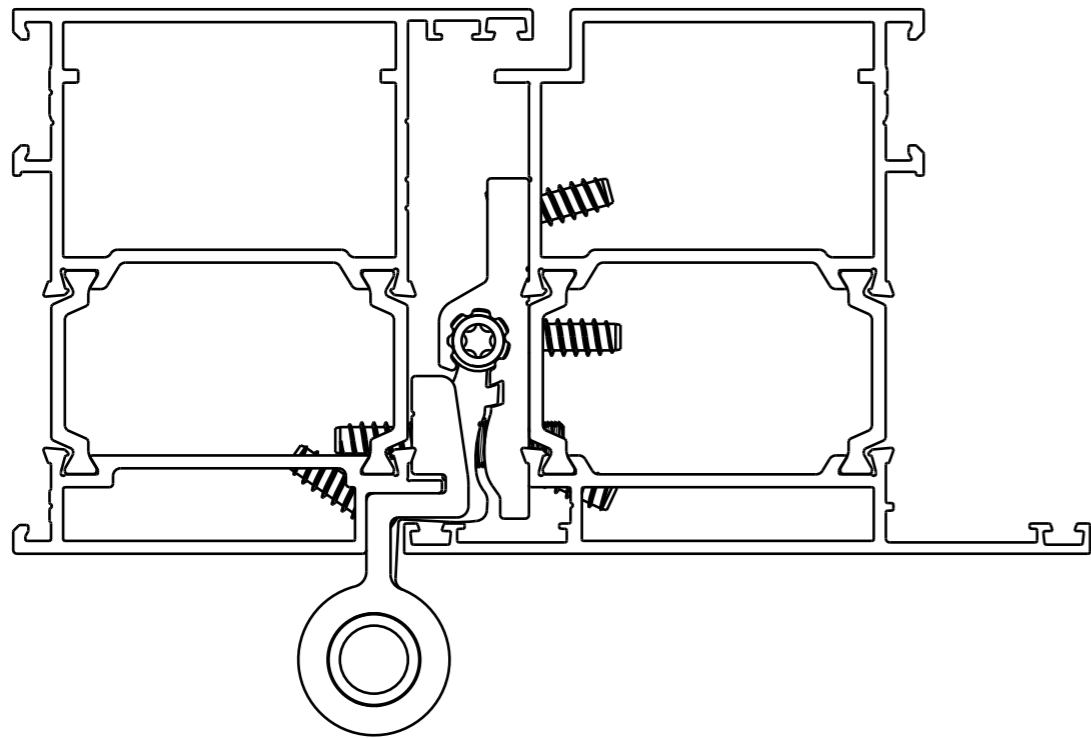
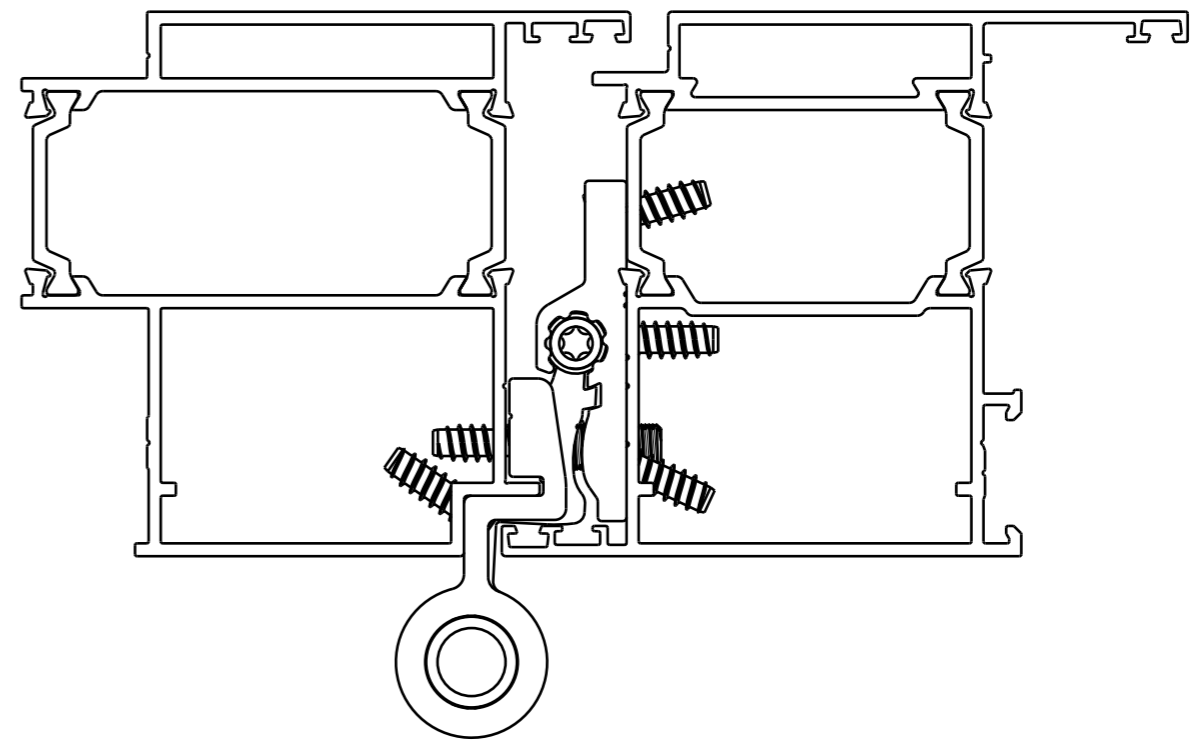
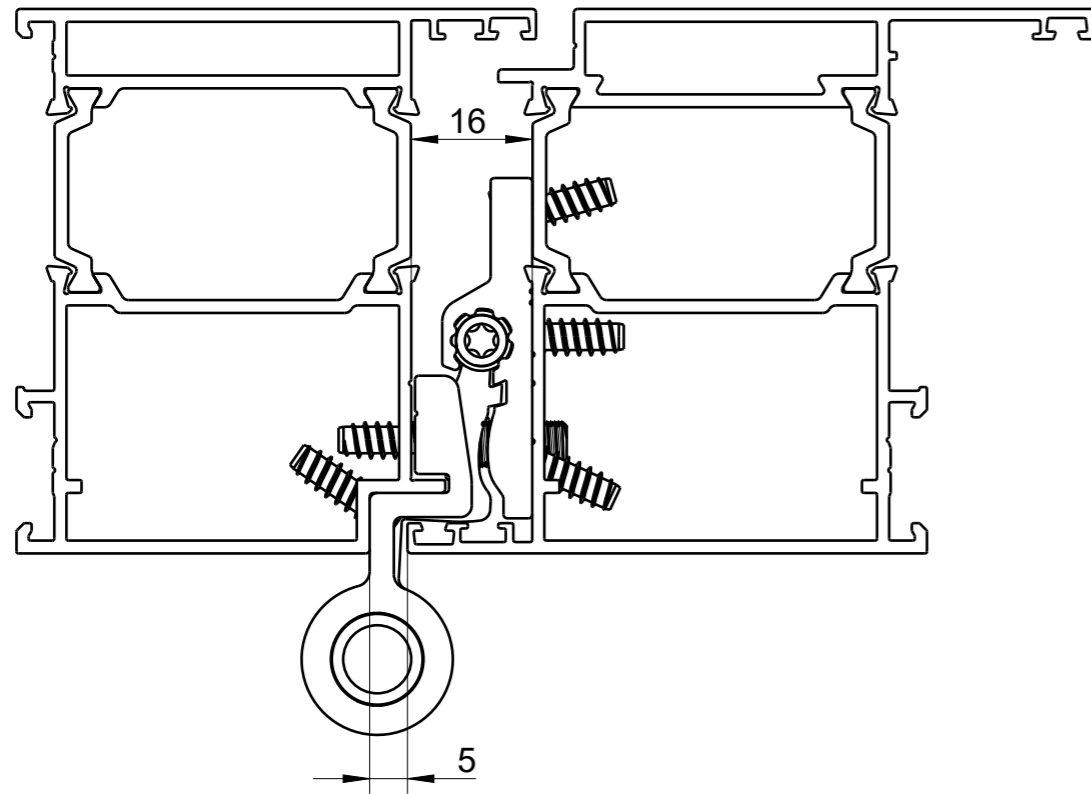

ASSEM

Für diese technischen Unterlagen behalten wir uns alle Rechte nach DIN ISO 16016 vor				Maßstab: 1:1		Gewicht: g	
				Maße ohne Toleranzangabe nur zur Information			
				Datum	Name	Benennung: NICHT Freigegeben!	
				Bear.	16.11.2021	KUDLA	
				Gepr.			
				Norm			
				DIS:	119673,ZDR,DRW,00		
				 Dr. Hahn [®] TÜRBÄNDER. MADE IN GERMANY.		Zeichnungsnummer:	
						233A0000	
				In.	Änderung	Datum	Name
				Urspr.:			
				Ers.f.		Modell-Nr. 233A0000	

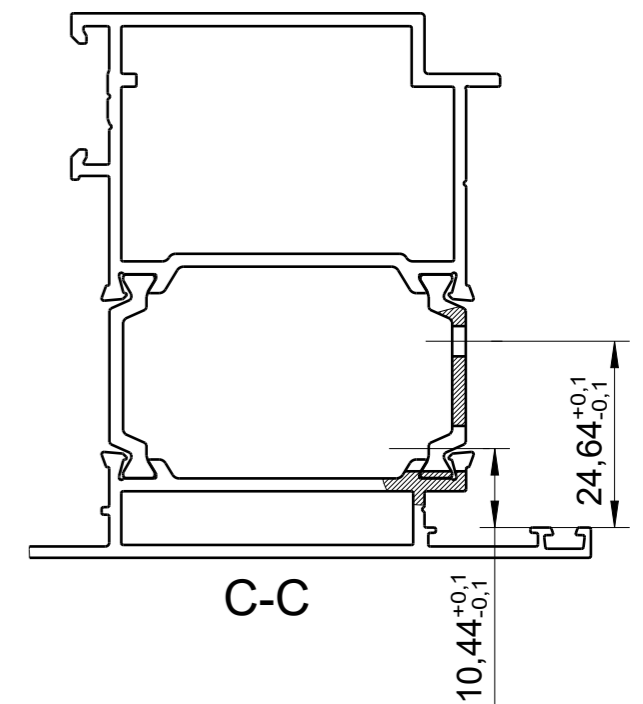
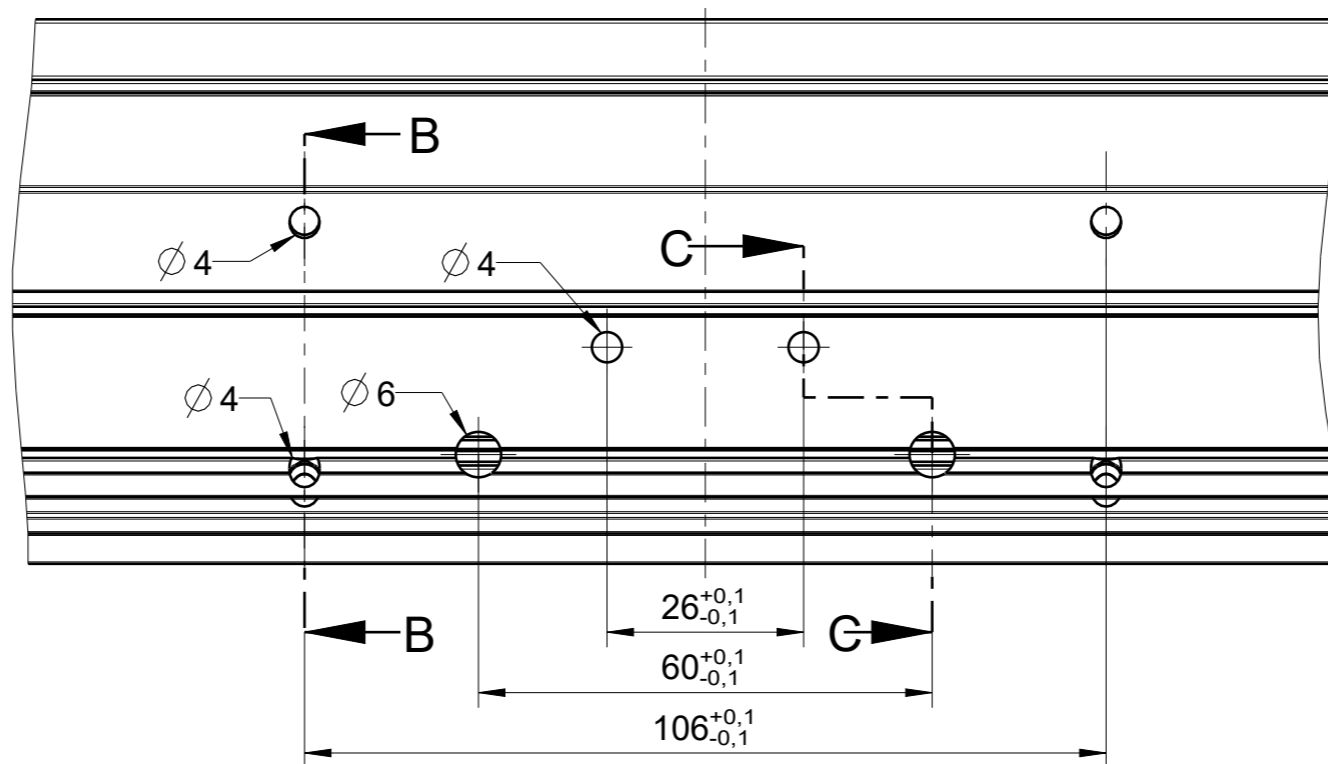
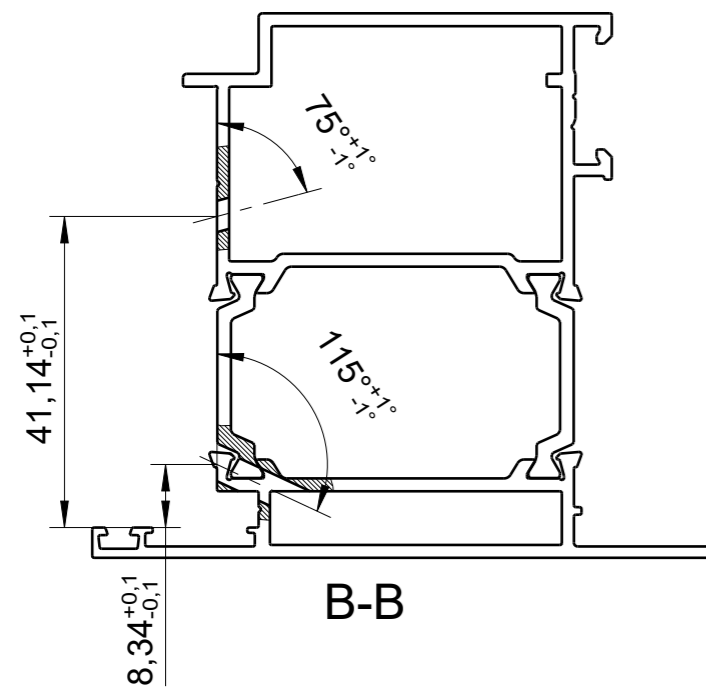
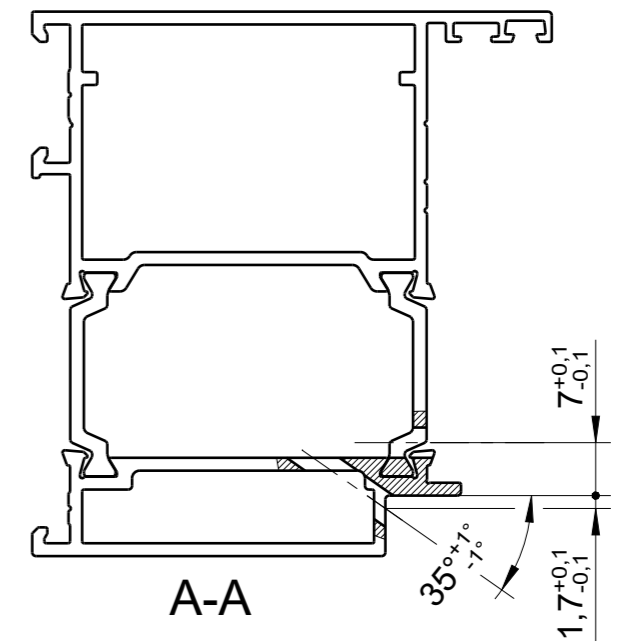
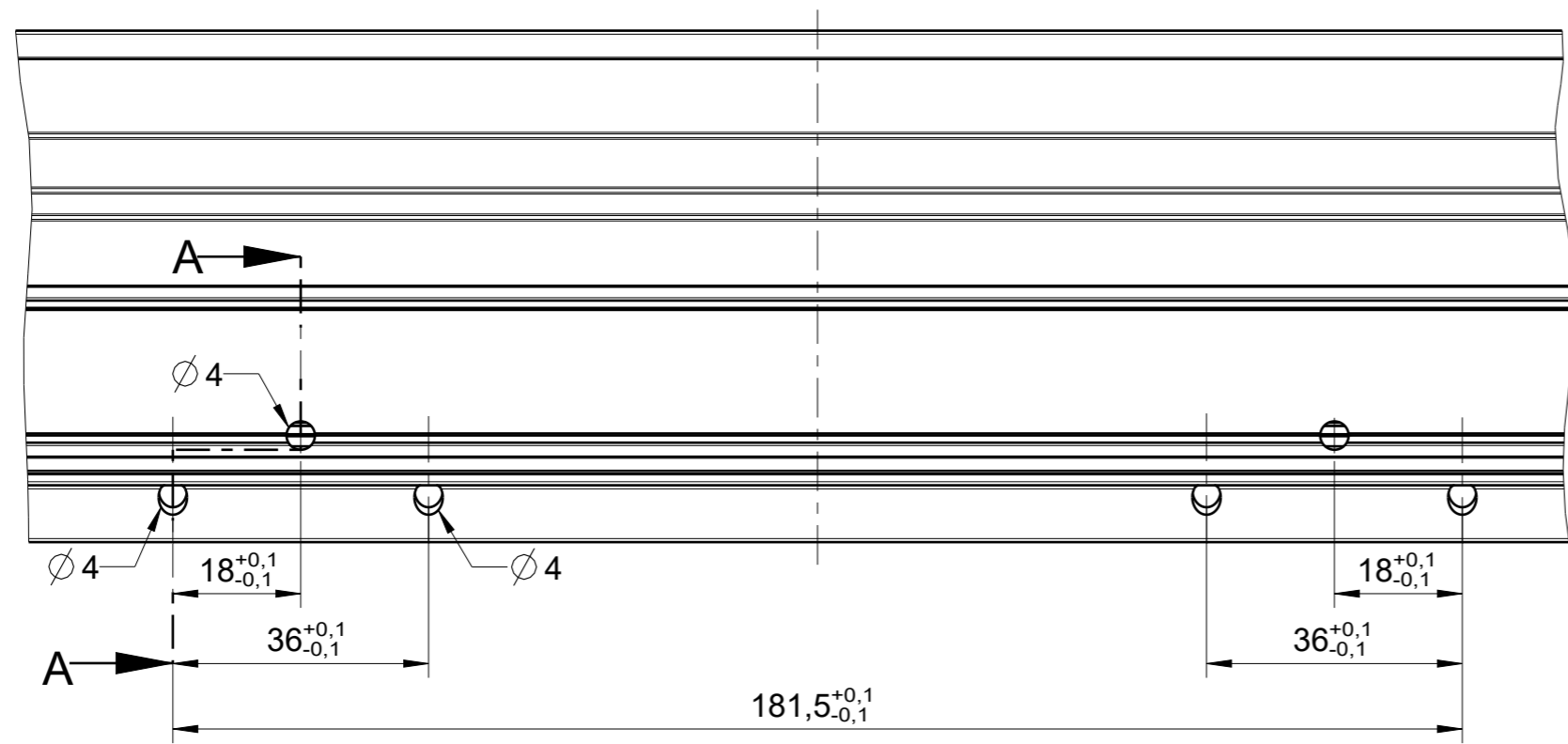

Für diese technischen Unterlagen behalten wir uns alle Rechte nach DIN ISO 16016 vor				Maßstab: 1:1	
				Maße ohne Toleranzangabe nur zur Information	
Bear.		Datum	Name	Benennung:	
Gepr.		16.11.2021	KUDLA	NICHT Freigegeben!	
Norm		Rollenband AT Tatprof MP72			
DIS:					
In.		Änderung		Zeichnungsnummer: 233A0000	
Datum		Name		Blatt	
Urspr.:		Ers.f.		5	
		Modell-Nr. 233A0000		6	

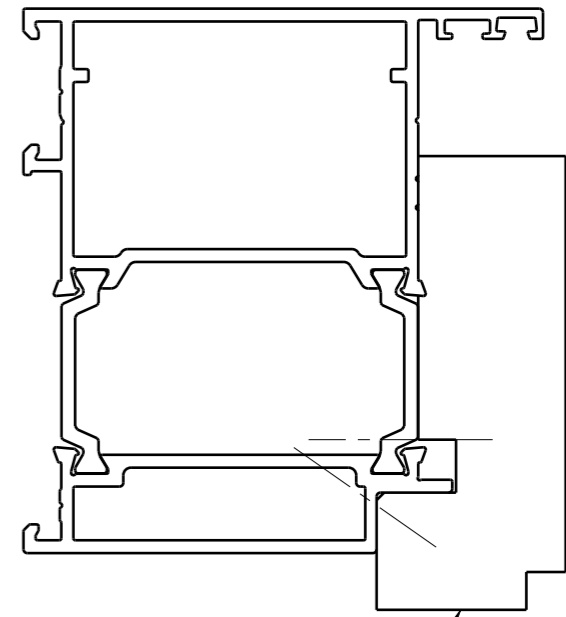
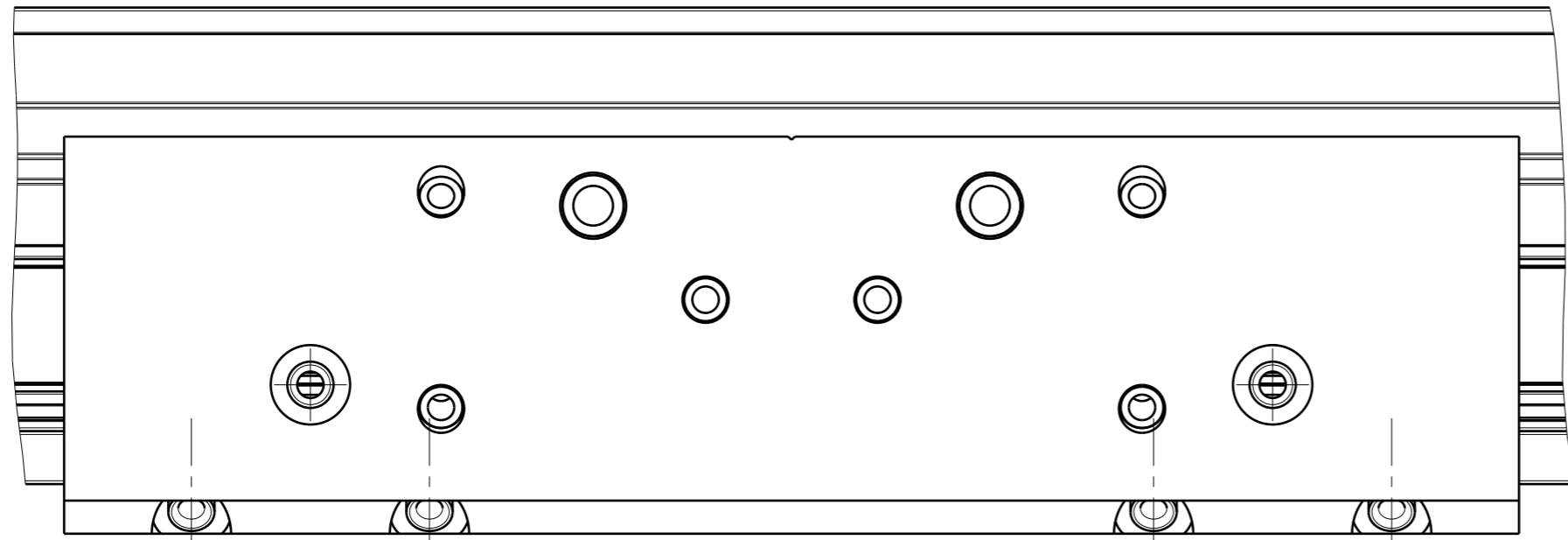

233B0010

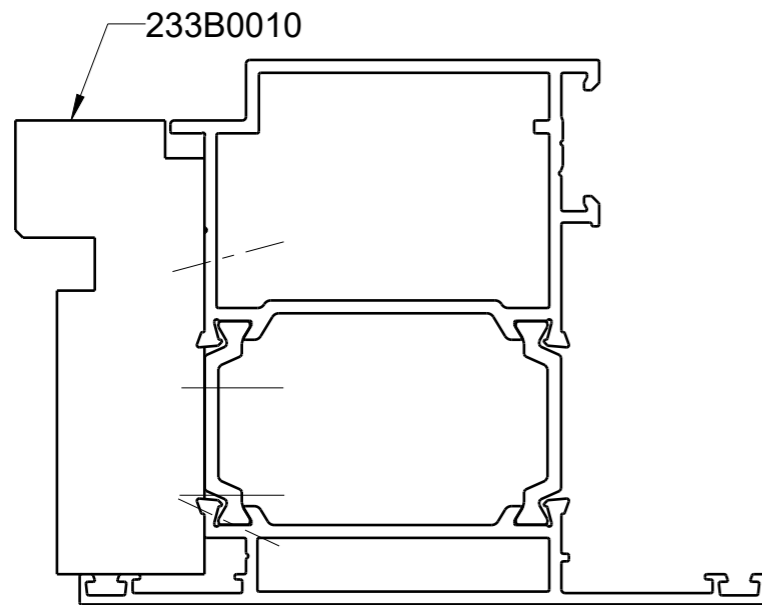

233B0010

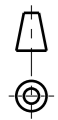
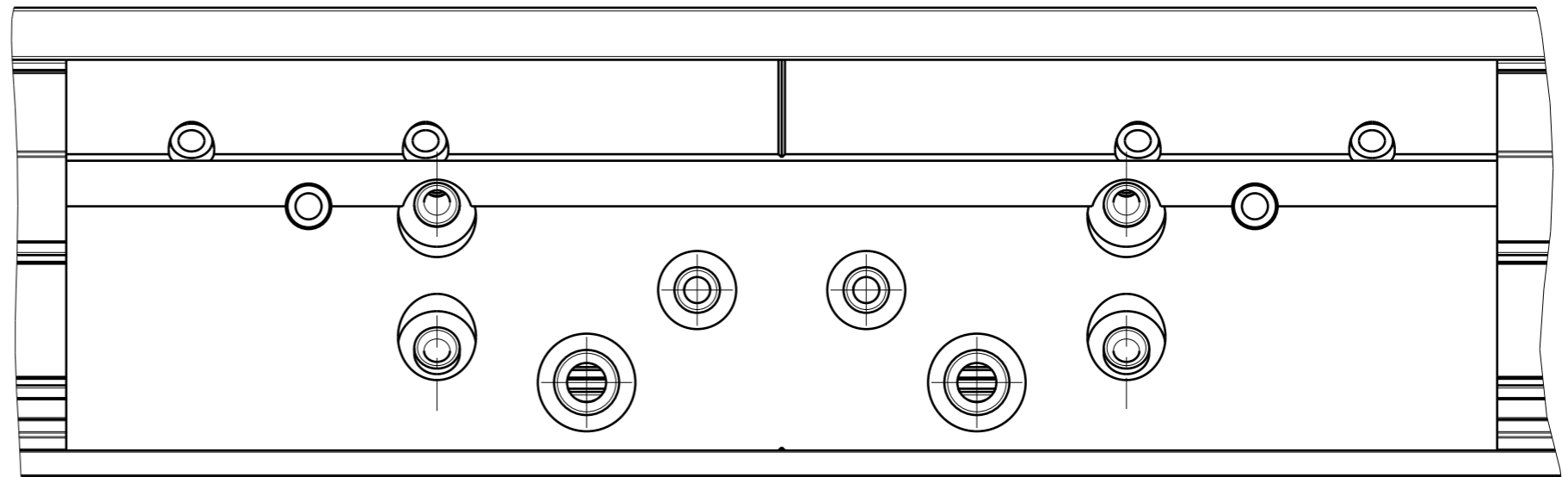

ASSEM

Für diese technischen Unterlagen behalten wir uns alle Rechte nach DIN ISO 16016 vor				Maßstab: 1:1		Gewicht: g			
				Maße ohne Toleranzangabe nur zur Information					
				Benennung:		NICHT Freigegeben!			
				Bear.	16.11.2021	KUDLA			
				Gepr.					
				Norm					
				DIS:	119673,ZDR,DRW,00				
				Dr. Hahn TÜRBÄNDER. MADE IN GERMANY.				Zeichnungsnummer:	
								233A0000	
						6			
						6			
In.	Änderung	Datum	Name	Urspr.:	Ers.f.	Modell-Nr. 233A0000			