

ASSEM

Für diese technischen Unterlagen behalten wir uns alle Rechte nach DIN ISO 16016 vor				Maßstab: 1:1	
				Maße ohne Toleranzangabe nur zur Information	
		Datum	Name	Benennung:	NICHT Freigegeben!
		Bear.	29.06.2021	KUDLA	
		Gepr.			
		Norm			
		DIS:	118918,ZDR,DRW,00		
		Dr. Hahn [®]		Zeichnungsnummer:	Blatt
		TÜRBÄNDER. MADE IN GERMANY.		R751_AT11_GEN	1
					5
In.	Änderung	Datum	Name	Urspr.:	Ers.f. Modell-Nr. R751_AT11_GEN

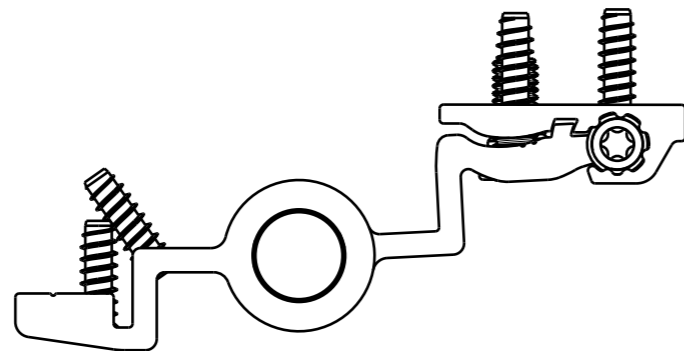

Pos	Menge	Benennung	Sachnummer
1	2	RBT AT 6 / 13,5	R700F0009
2	2	Lagerbuchse FBT exzentrisch schwarz	R600K0001
3	1	FBT Einheit komplett Rollenband AT	R700B0022
4	1	Lagerbolzen	R600E0007
5	2	Gewindestift M6x5-TX15 A4 oder A2	R400E0010
6	10	Bef.-Schraube RB-AT 4,8x16	R700E0000

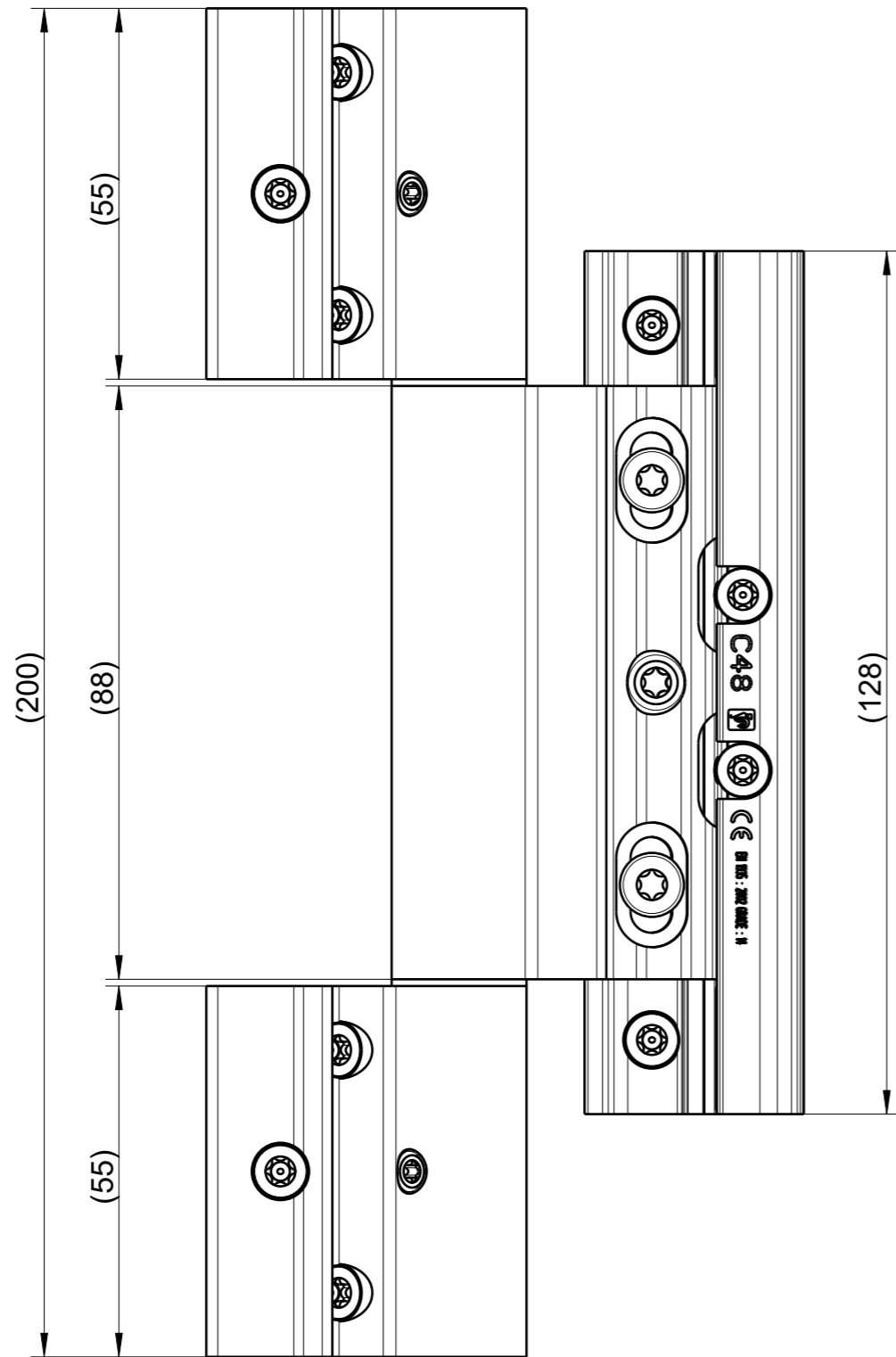
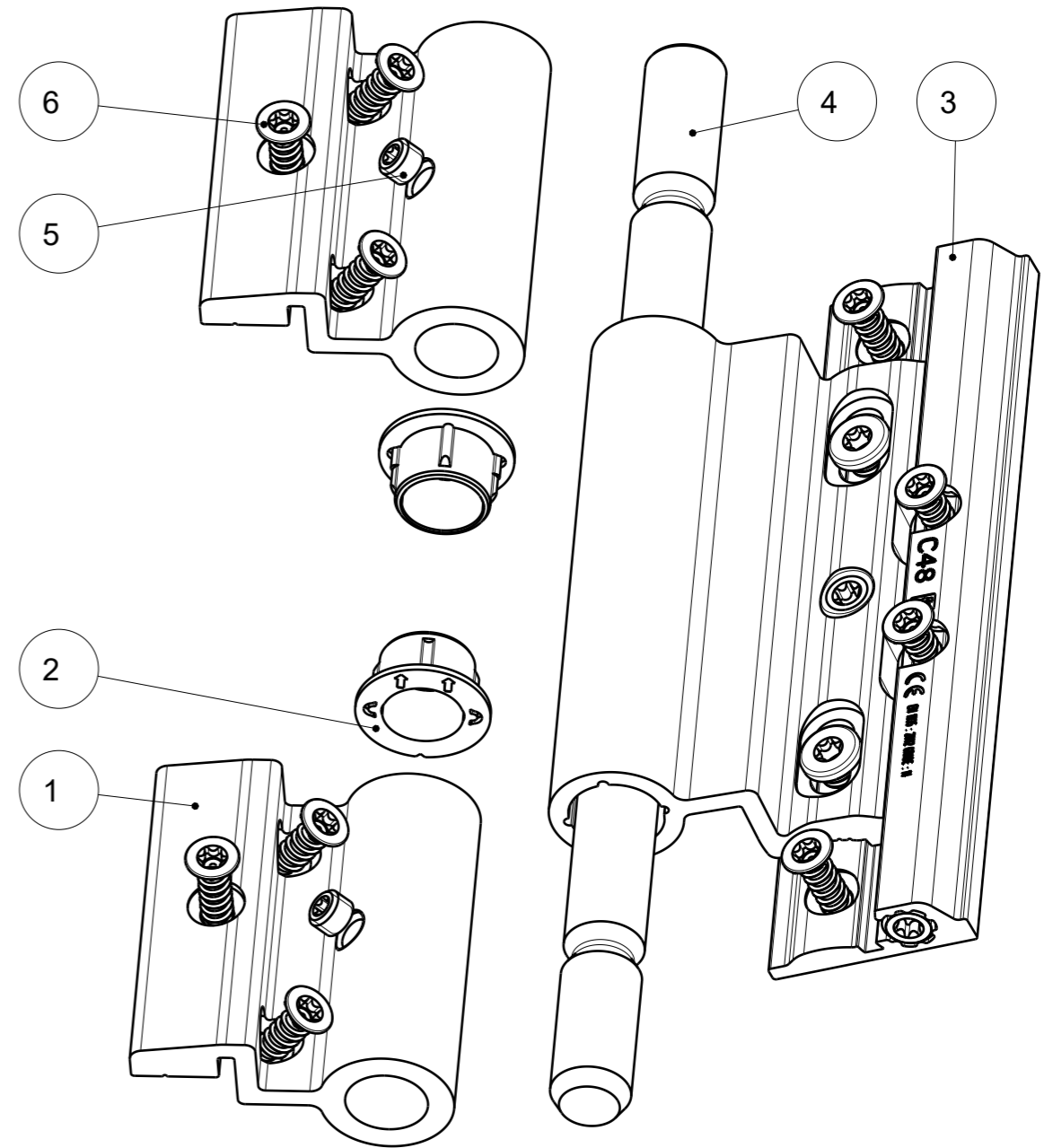

Für diese technischen Unterlagen behalten wir uns alle Rechte nach DIN ISO 16016 vor				Maßstab: 1:1	
				Maße ohne Toleranzangabe nur zur Information	
		Datum	Name	Benennung: NICHT Freigegeben!	
		Bear. 29.06.2021	KUDLA	Rollenband AT Alutech C48	
		Gepr.			
		Norm		Zeichnungsnummer: Blatt	
		DIS: 118918_ZDR,DRW,00		R751_AT11_GEN 2	
				5	
In.	Änderung	Datum	Name	Urspr.:	Ers.f. Modell-Nr. R751_AT11_GEN

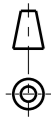
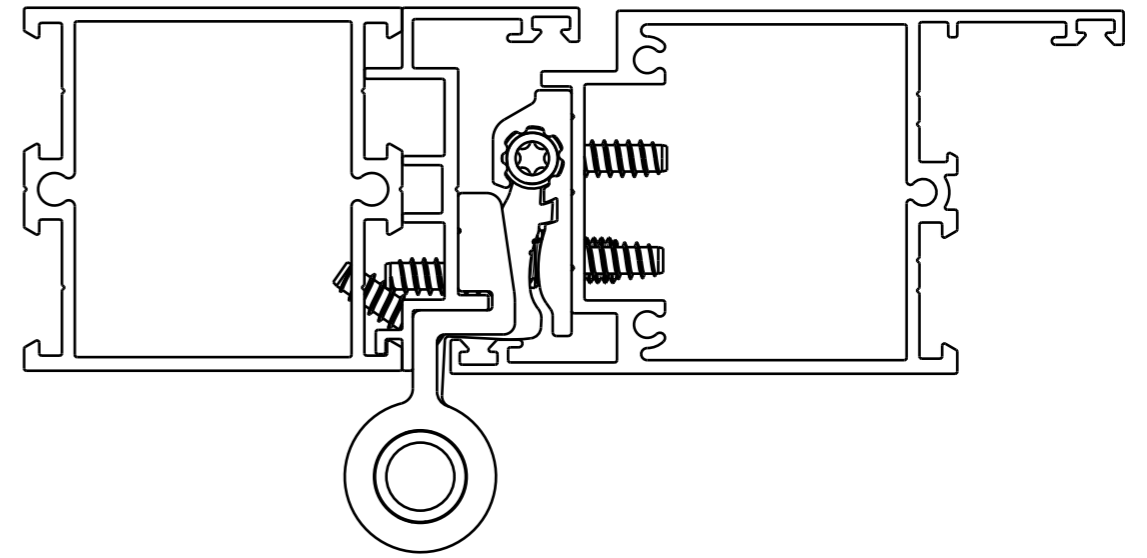
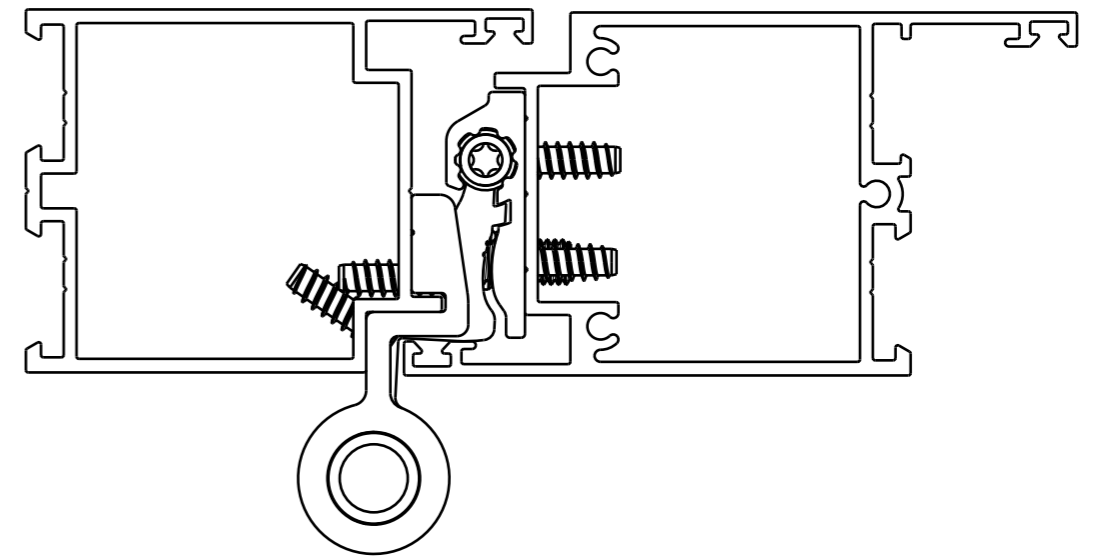
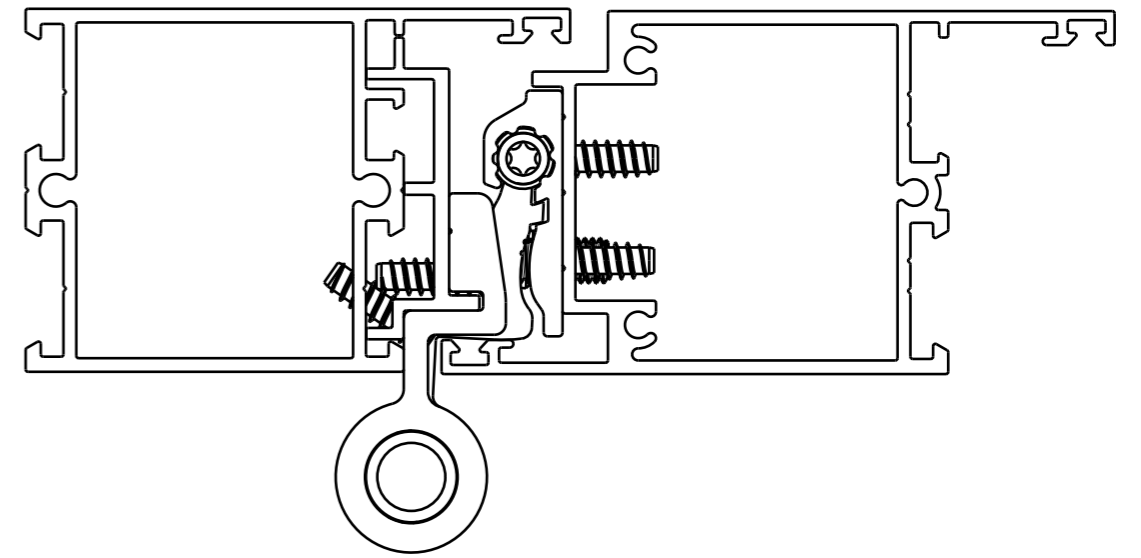
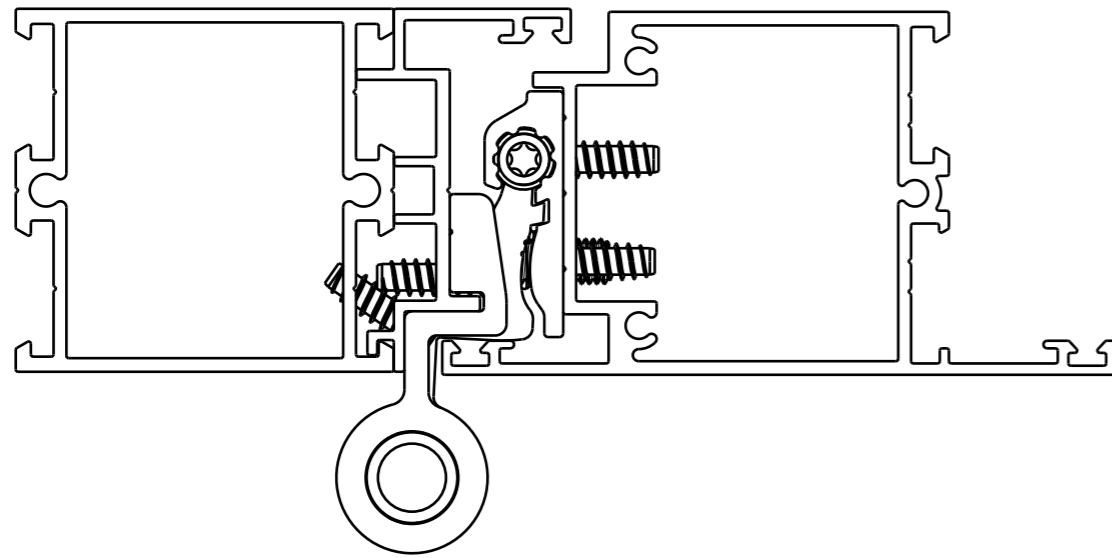
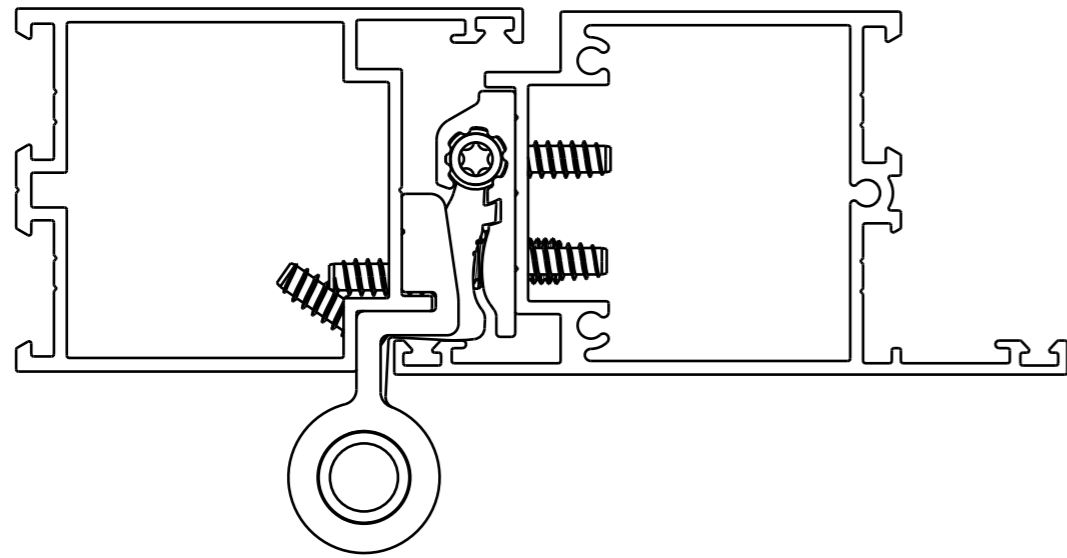
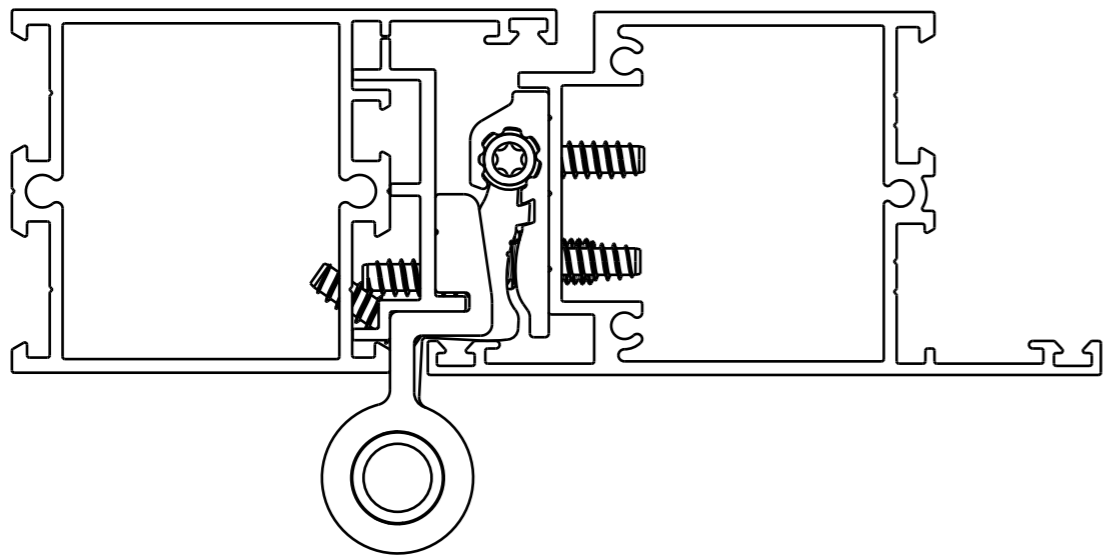

ASSEM

Für diese technischen Unterlagen behalten wir uns alle Rechte nach DIN ISO 16016 vor				Maßstab: 1:1		
				Maße ohne Toleranzangabe nur zur Information		
		Datum	Name	Benennung:	NICHT Freigegeben!	
	Bear.	29.06.2021	KUDLA	Rollenband AT Alutech C48		
	Gepr.					
	Norm					
	DIS:	118918_ZDR,DRW,00			Zeichnungsnummer:	Blatt
				R751_AT11_GEN		3
						5
In.	Änderung	Datum	Name	Urspr.:	Ers.f.	Modell-Nr. R751_AT11_GEN



TÜRBÄNDER. MADE IN GERMANY.

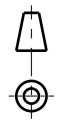
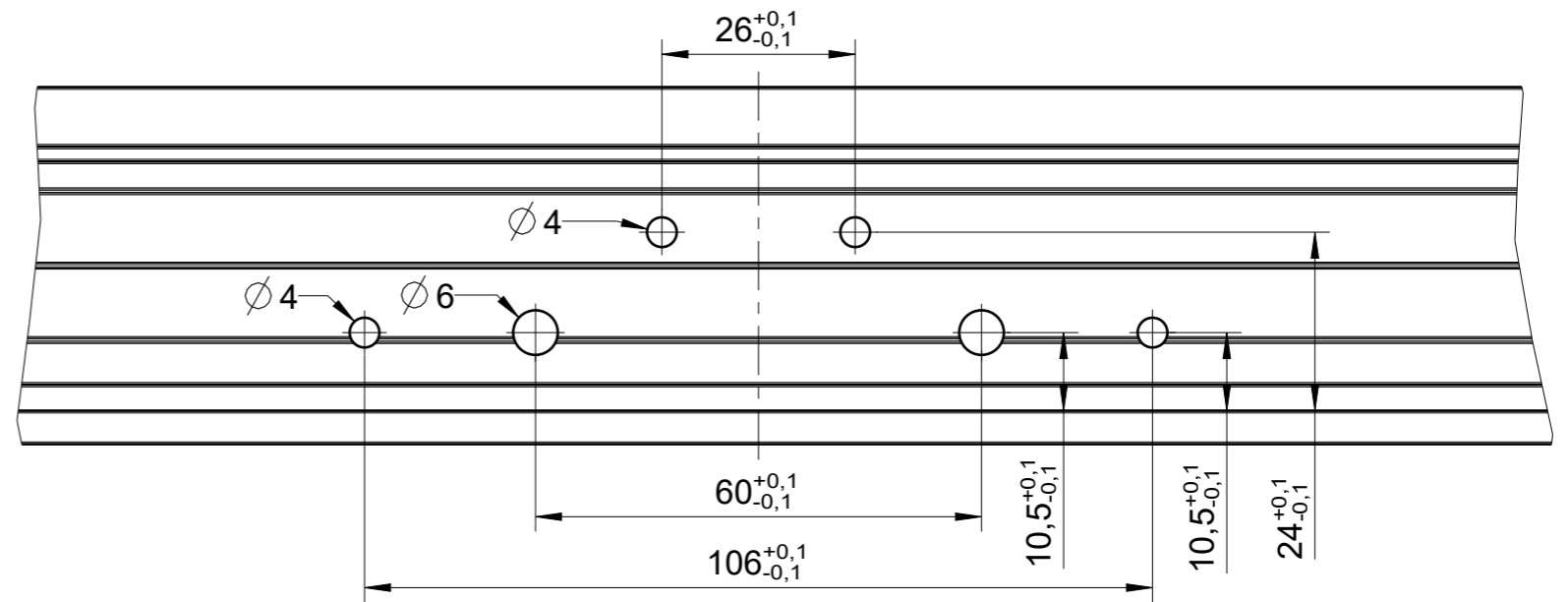
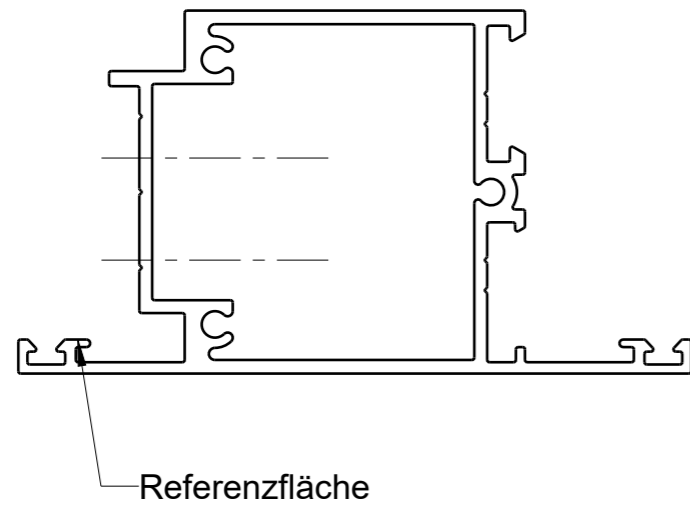
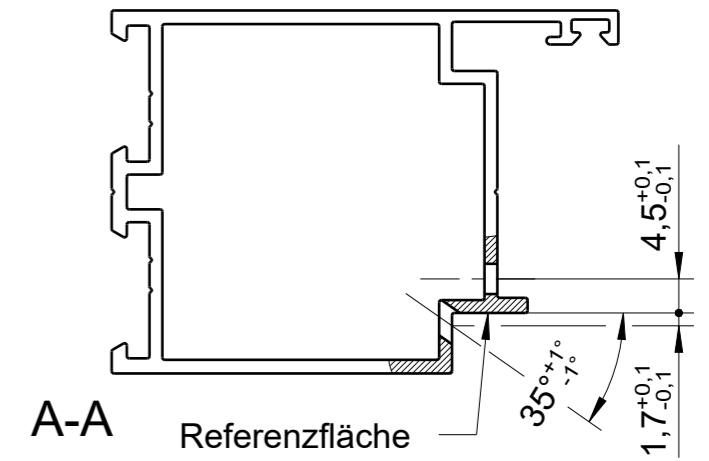
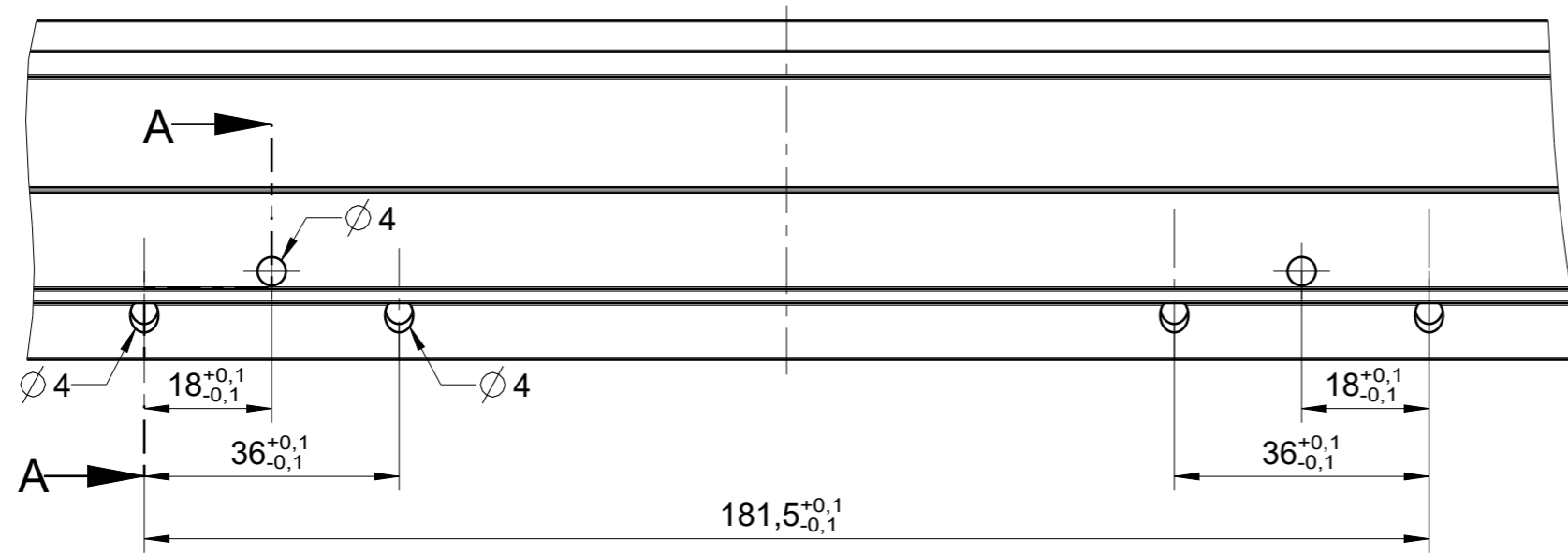

ASSEM

Für diese technischen Unterlagen behalten wir uns alle Rechte nach DIN ISO 16016 vor				Maßstab: 1:1		Gewicht: g	
				Maße ohne Toleranzangabe nur zur Information			
				Benennung:		NICHT Freigegeben!	
				Datum		Name	
				Bear. 29.06.2021		KUDLA	
				Gepr.			
				Norm			
				DIS: 118918,ZDR,DRW,00			
				Dr. Hahn TÜRBÄNDER. MADE IN GERMANY.		Zeichnungsnummer:	
						R751_AT11_GEN	
				Ers.f.		Modell-Nr. R751_AT11_GEN	
In.	Änderung	Datum	Name	Urspr.:			

4
5

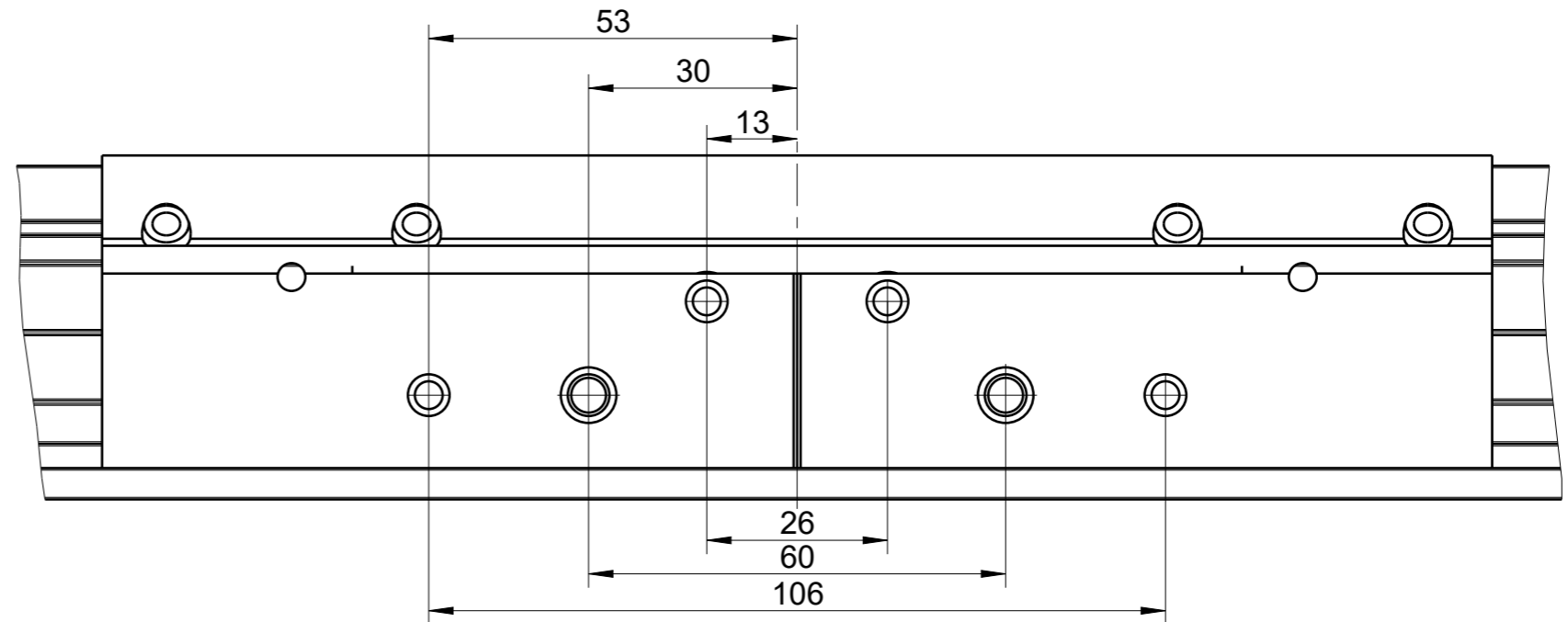
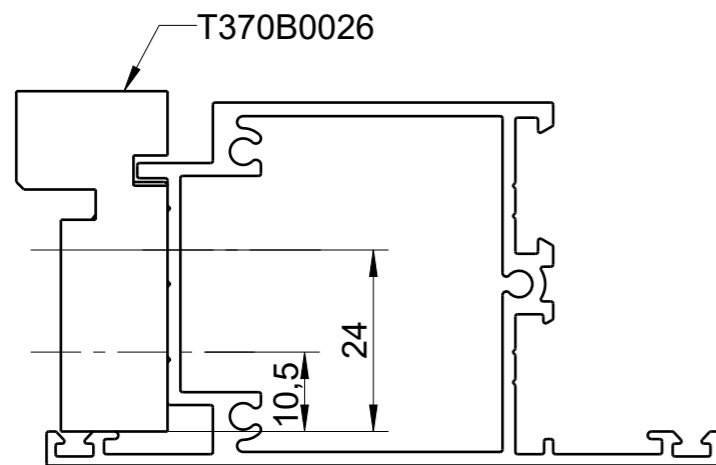
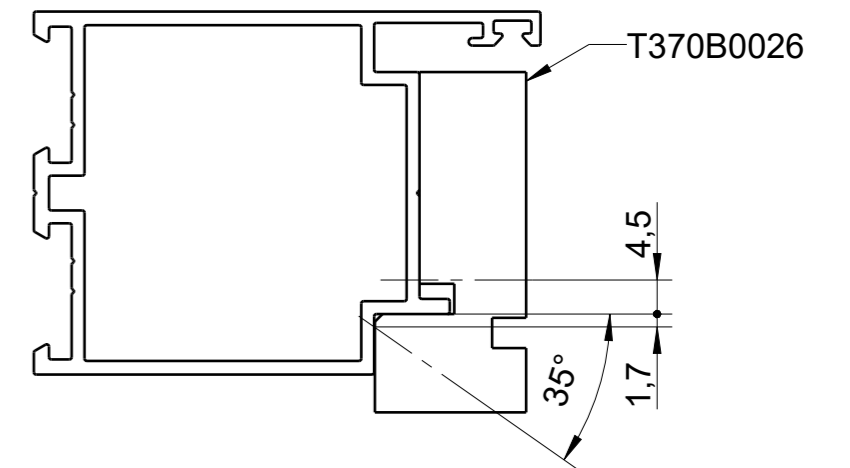
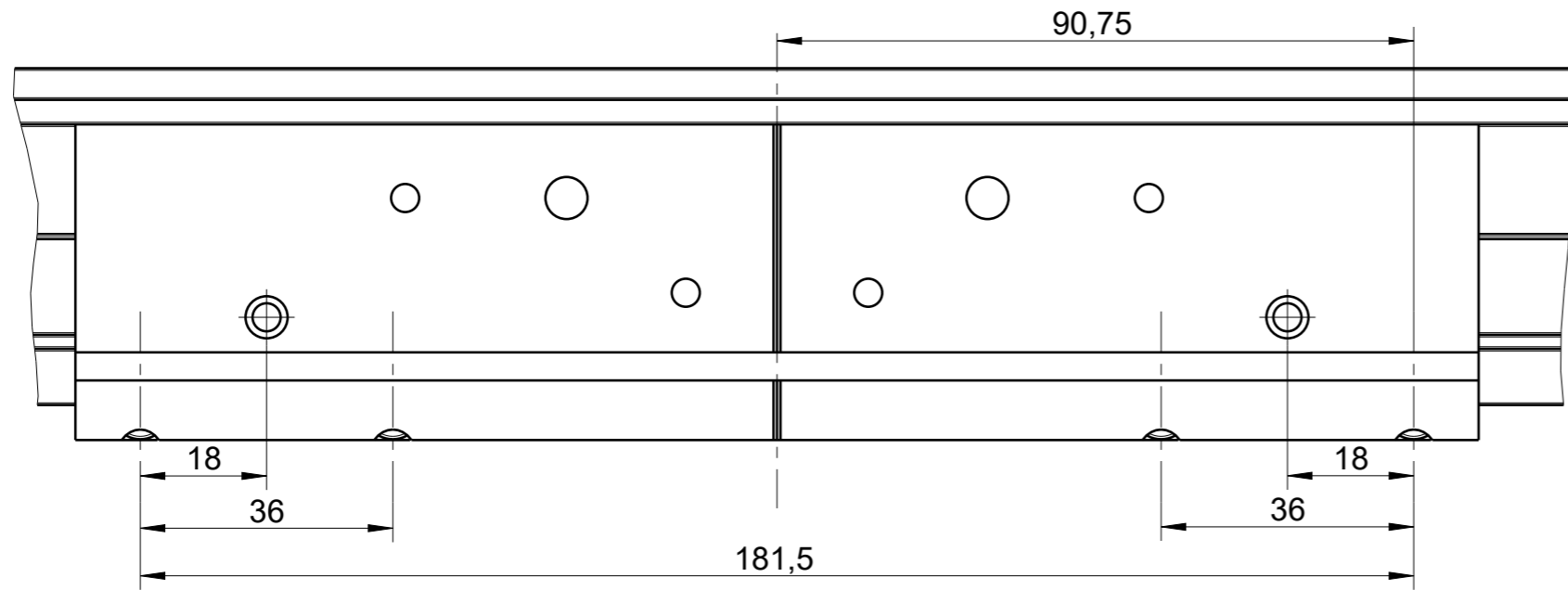

Für diese technischen Unterlagen behalten wir uns alle Rechte nach DIN ISO 16016 vor				Maßstab: 1:1		Gewicht: g	
				Maße ohne Toleranzangabe nur zur Information			
				Benennung:		NICHT Freigegeben!	
				Datum		Name	
				Bear. 29.06.2021		KUDLA	
				Gepr.			
				Norm			
				DIS: 118918,ZDR,DRW,00			
				Dr. Hahn TÜRBÄNDER. MADE IN GERMANY.		Zeichnungsnummer:	
						R751_AT11_GEN	
				Ers.f.		Modell-Nr. R751_AT11_GEN	
In.	Änderung	Datum	Name	Urspr.:			